

Over 5000 VXI cards and mainframes in stock. 1000's of pieces of Test Equipment in stock.



Looking for Test Equipment?  
Visit us on the web at  
[www.recycledequipment.com](http://www.recycledequipment.com)

Recycled Equipment buys, sells, and repairs VXI cards, VXI mainframes and Test Equipment. We have tens of thousands of pieces of Electronic Test Equipment and one of the worlds largest selections of VXI cards. We have VXI cards by almost every manufacture; from Agilent to Ziatech. **Every item on our website is IN STOCK and ready to ship with in 24 hours.**

### **Sell your equipment for cash**

Recycled Equipment is interested in buying your surplus equipment! Call us today at **(410)685-1997** or email to **recycled@usimperio.com**

### **Sell your equipment on consignment**

Recycled Equipment can sell your equipment on consignment. This allows you to get retail prices for your equipment with out the hassle.

**(410)685-1997 sales@recycledequipment www.recycledequipment.com**

# SERIES ATE



ATE Models with analog meters

Series ATE power supplies are precision analog-controlled power supplies. They feature high gain and zeroable offsets to follow voltage signals or variable resistance controls precisely. An optional fast mode provides fast programming response into the mid audio range. The voltage and current channels are equally controllable with automatic crossover between modes.

For a series of full rack sized 1000 watt, keypad controlled ATE models with built-in GPIB control, see Series ATE-DMG, page 28.

## FEATURES

- Linear programmable power in five sizes to 1000 watts.
- Low noise, high speed linear precision control.
- Voltage and current stabilization.
- 10 turn panel controls offer exceptional resolution.
- User-selectable capacitorless output for fast analog programming or quick recovery current-mode operation.



**CE** ATE are CE marked per the Low Voltage Directive (LVD), EN61010-1.

Panel mounted analog meters allow monitoring of both channels. Optionally, ATE models can be provided with digital displays. To specify, substitute the suffix "DM" for the suffix "M" in the model number. For example: ATE 36-15DM specifies digital displays. Local control of both channels is by panel-mounted 10-turn rheostats. Panel mounted LEDs indicate voltage or current mode operation. This information is simultaneously delivered as an optically isolated TTL-compatible flag signal accessible through the rear connector.



Model ATE 15-50DM with optional digital meters  
0-15 Volt, 0-50 Ampere model

The tabulation of the effective series resistance and inductance in voltage mode, and the effective shunt resistance and shunt capacitance in current mode, is done to allow a calculation of the output impedance versus frequency.

## ATE MODEL TABLE

MODEL(4)	d-c OUTPUT RANGE		OUTPUT IMPEDANCE VOLTAGE MODE			OUTPUT IMPEDANCE CURRENT MODE		
	VOLTS	AMPS	SERIES R	SERIES L (1)	FAST	SHUNT R (2)	SHUNT C (3)	FAST
<b>QUARTER-RACK (50 Watt)</b>								
ATE 6-5M	0-6	0-5	24μΩ	0.5μH	5μH	12kΩ	1,000μF	1μF
ATE 15-3M	0-15	0-3	100μΩ	0.5μH	5μH	30kΩ	450μF	0.4μF
ATE 25-2M	0-25	0-2	250μΩ	1μH	10μH	50kΩ	250μF	0.25μF
ATE 36-1.5M	0-36	0-1.5	480μΩ	1μH	10μH	72kΩ	200μF	0.2μF
ATE 55-1M	0-55	0-1	1.1mΩ	2μH	20μH	110kΩ	150μF	0.15μF
ATE 75-0.7M	0-75	0-0.7	2.15mΩ	2μH	20μH	150kΩ	110μF	0.1μF
ATE 100-0.5M	0-100	0-0.5	4mΩ	4μH	40μH	200kΩ	47μF	0.05μF
ATE 150-0.3M	0-150	0-0.3	10mΩ	4μH	40μH	300kΩ	475μF	0.02μF
<b>QUARTER-RACK (100 Watt)</b>								
ATE 6-10M	0-6	0-10	12μΩ	0.5μH	5μH	12kΩ	1,800μF	2μF
ATE 15-6M	0-15	0-6	50μΩ	0.5μH	5μH	30kΩ	1,000μF	0.8μF
ATE 25-4M	0-25	0-4	125μΩ	1μH	10μH	50kΩ	500μF	0.5μF
ATE 36-3M	0-36	0-3	240μΩ	1μH	10μH	72kΩ	350μF	0.4μF
ATE 55-2M	0-55	0-2	0.55mΩ	2μH	20μH	110kΩ	200μF	0.3μF
ATE 75-1.5M	0-75	0-1.5	1mΩ	2μH	20μH	150kΩ	110μF	0.2μF
ATE 100-1M	0-100	0-1	2mΩ	4μH	40μH	200kΩ	80μF	0.1μF
ATE 150-0.7M	0-150	0-0.7	4mΩ	4μH	40μH	300kΩ	475μF	0.04μF
<b>HALF-RACK (250 Watt)</b>								
ATE 6-25M	0-6	0-25	4.8μΩ	0.5μH	5μH	12kΩ	11,000μF	5μF
ATE 15-15M	0-15	0-15	20μΩ	0.5μH	5μH	30kΩ	5,800μF	2μF
ATE 25-10M	0-25	0-10	50μΩ	1μH	10μH	50kΩ	2,900μF	1.25μF
ATE 36-8M	0-36	0-8	90μΩ	1μH	10μH	72kΩ	2,400μF	1μF
ATE 55-5M	0-55	0-5	0.22mΩ	2μH	20μH	110kΩ	1,400μF	0.75μF
ATE 75-3M	0-75	0-3	0.5mΩ	2μH	20μH	150kΩ	850μF	0.5μF
ATE 100-2.5M	0-100	0-2.5	0.8mΩ	4μH	40μH	200kΩ	375μF	0.25μF
ATE 150-1.5M	0-150	0-1.5	2mΩ	4μH	40μH	300kΩ	275μF	0.1μF
ATE 325-0.8M	0-325	0-0.8	8.1mΩ	100μH	1μH	650kΩ	180μF	0.01μF
<b>THREE-QUARTER-RACK (500 Watt)</b>								
ATE 6-50M	0-6	0-50	2.4μΩ	0.5μH	5μH	12kΩ	12,000μF	10μF
ATE 15-25M	0-15	0-25	12μΩ	0.5μH	5μH	30kΩ	8,000μF	4μF
ATE 25-20M	0-25	0-20	25μΩ	1μH	10μH	50kΩ	5,800μF	2.5μF
ATE 36-15M	0-36	0-15	48μΩ	1μH	10μH	72kΩ	4,900μF	2μF
ATE 55-10M	0-55	0-10	0.11mΩ	2μH	20μH	110kΩ	2,900μF	1.5μF
ATE 75-8M	0-75	0-8	0.19mΩ	2μH	20μH	150kΩ	1,200μF	1μF
ATE 100-5M	0-100	0-5	0.4mΩ	4μH	40μH	200kΩ	600μF	0.5μF
ATE 150-3.5M	0-150	0-3.5	0.86mΩ	4μH	40μH	300kΩ	440μF	0.2μF
<b>FULL-RACK (1000 Watt)</b>								
ATE 6-100M	0-6	0-100	1.2μΩ	0.5μH	5μH	12kΩ	22,000μF	15μF
ATE 15-50M	0-15	0-50	6μΩ	0.5μH	5μH	30kΩ	12,000μF	6μF
ATE 25-40M	0-25	0-40	12.5μΩ	1μH	10μH	50kΩ	11,000μF	4μF
ATE 36-30M	0-36	0-30	24μΩ	1μH	10μH	72kΩ	9,500μF	3μF
ATE 55-20M	0-55	0-20	55μΩ	2μH	20μH	110kΩ	5,200μF	2.25μF
ATE 75-15M	0-75	0-15	0.1mΩ	2μH	20μH	150kΩ	3,400μF	1.5μF
ATE 100-10M	0-100	0-10	0.2mΩ	4μH	40μH	200kΩ	1,200μF	0.75μF
ATE 150-7M	0-150	0-7	0.42mΩ	4μH	40μH	300kΩ	1,050μF	0.3μF

- (1) For determining dynamic impedance in voltage mode.
- (2) Based on 0.5mA load effect in FAST mode.
- (3) For determining dynamic impedance in current mode.
- (4) Add suffix "DM" to specify dual 3½ digit LCD displays in place of analog meters.

## ATE STATIC SPECIFICATIONS

INFLUENCE QUANTITY	OUTPUT EFFECTS VOLTAGE MODE		OUTPUT EFFECTS CURRENT MODE		OFFSETS	
	Typ.	Max.	Typ.	Max.	ΔE <sub>io</sub>	ΔI <sub>io</sub>
Source Voltage (min.-max.)	<0.0005% E <sub>0</sub> max.	0.001% E <sub>0</sub> max.	<0.002% I <sub>0</sub> max.	0.005% I <sub>0</sub> max.	<1μV	<1nA
Load (no load-full load)	<0.001% E <sub>0</sub> max.	0.002% E <sub>0</sub> max.	<0.5 mA(1)	1 mA(1)	—	—
Time (8-hour drift)	<0.005% E <sub>0</sub> max.	0.01% E <sub>0</sub> max.	<0.01% I <sub>0</sub> max.	0.02% I <sub>0</sub> max.	<20μV	<1nA
Temperature, per °C	<0.005% E <sub>0</sub> max.	0.01% E <sub>0</sub> max.	<0.01% I <sub>0</sub> max.	0.02% I <sub>0</sub> max.	<20μV	<2nA
Ripple and Noise (2)	rms: p-p:(3)	<0.1mV 3mV	<0.01% I <sub>0</sub> max. <0.1% I <sub>0</sub> max.	0.03% I <sub>0</sub> max. 0.3% I <sub>0</sub> max.	—	—
Ripple and Noise (2)	rms: p-p:(3)	<1mV 30mV(4)	<0.01% I <sub>0</sub> max. <0.1% I <sub>0</sub> max.	0.03% I <sub>0</sub> max. 0.3% I <sub>0</sub> max.	—	—

- (1) For I<sub>0</sub>>50A, load effect = 2mA typ., 5mA max. In slow mode, the output capacitor adds 0-6mA to current mode load effect.
- (2) One terminal grounded so that common mode current does not flow through load or current-sense resistor.
- (3) BW: 20Hz-10MHz.
- (4) For high voltage ATE 325-0.8M the maximum output ripple and noise is 10mV rms and 50mV p-p.

## FEATURES

- User selectable fast or conventional modes of operation. Use fast-mode for rapid response to programmed instructions or for quick response in current mode to load changes.
- Voltage and current modes with full and equal control over the output in both modes.
- Multi-terminal user port allows the ATE to be configured by arranging the jumpers on a mating plug, PC-12.
- Full zeroing and full-scale calibration for both the voltage and current control channels.
- Programmable overvoltage crowbar. Can be manually set from the panel or programmed with a 0-10V analog signal. Optically isolated input-output to interconnect multiple power supplies.
- Uncommitted amplifiers to manipulate arbitrary control signals into the required 0-10V needed to program ATE. Two provided. Can be used for scaling and summing.
- Digital control through SN-series IEEE-488 interfaces.
- The variation of the ATE's voltage and current offsets as a function of source, time and temperature are tabulated in the static specifications table. These may be used to calculate the output effect by the relationship:  

$$\Delta E_o = \pm \Delta E_r (R_f/R_i) \pm \Delta E_{io} (1 + R_f/R_i) \pm \Delta I_{io} (R_f/R_i)$$
 where R<sub>f</sub> is the feedback resistor, and R<sub>i</sub> is the input resistor from the reference, E<sub>r</sub>.

The tabulated offsets, more particularly their change as a function of source, time and temperature, allow a user to calculate performance of the uncommitted amplifier(s) with user specified input and feedback components. The formula for this is given above.

**TABLE 1**

Source current, measured worst case, 125V a-c.

	AMPS
Size A	1.4
Size B	2.4
Size C	6.0
Size D	11.0
Size E	20.0

**TABLE 2**

**ATE DYNAMIC SPECIFICATIONS**

OUTPUT VOLTAGE RATING	PROGRAMMING BANDWIDTH (minimum)	PROGRAMMING TIME CONSTANT (maximum)
6V	16.0KHz	10µsec
15V	10.6KHz	15µsec
25V	8.0KHz	20µsec
36V	6.4KHz	25µsec
55V	4.0KHz	40µsec
75V	3.5KHz	45µsec
100V	2.5KHz	65µsec
150V	1.7KHz	95µsec
325V	937.0Hz	170µsec



Model ATE 75-0.7M Quarter Rack



Model ATE 55-5M Half Rack



Model ATE 25-20M Three Quarter Rack



Model ATE 55-20M Full Rack

**ATE GENERAL SPECIFICATIONS**

SPECIFICATION	RATING/DESCRIPTION	CONDITION
<b>INPUT</b>		
a-c Voltage	95-113, 105-125, 190-226, 210-250V a-c	User selectable
Current	See Table 1	Max load, 115V a-c
Frequency	47-65Hz	Range
<b>OUTPUT</b>		
d-c Output	Series pass	Transistor (1)
Type of Stabilizer	Automatic crossover	Voltage/current
Voltage	0 to 100% of rating	Adjustment range for temp 0-55°C
Current	0 to 100% of rating	
	0 to 90% of rating	For temp 65°C
Error Sense	0.5V per load wire(2)	Voltage allowance
Isolation Voltage	500V d-c or peak	Output to ground
Leakage Current	<5 microamperes	rms at 115V a-c
Output to Ground	<50 microamperes	p-p at 115V a-c
Series Connection	500V	Max voltage off ground
Parallel Connection	Automatic	Use current mode limiting
	Current sharing	Use master-slave connection
	Redundancy type	External or-ing diodes
OVP Type Control	Crowbar	
	Local or program or track	
	50 microseconds	Trigger time: normal
	500 microseconds	Trigger time: delayed
<b>CONTROL</b>		
Type	Voltage	Variable input, fixed gain
	Current	Differential comparison
Voltage	Local	10-turn precision rheostat
	Remote Analog	0 to 10 Volts d-c
	Remote Digital	Use SN or SNR interface
Current	Local	10-turn precision rheostat
	Remote Analog	0 to 1 Volt d-c
	Remote Digital	Use SN or SNR interface
Dynamics	Normal (slow)	dV/dt=I/C
	Fast mode	See Table 2
<b>MECHANICAL</b>		
Input Connection	Detachable IEC type 3-wire	1/4, 1/2, 3/4 rack size
	Hard wired	Full size rack
Output Connections	Rear barrier strip	1/4 rack size
	Rear binding posts	All models: I <sub>o</sub> <30A
	Rear compression studs	All models: I <sub>o</sub> ≥30A
User Port	50-terminal connector	All sizes
Meters	1½-2½ meters	Analog, 3%
	3 digit LCD	Digital (optional)
Indicators	Three LEDs	Voltage/Current/OVP
Mounting (in std 19" racks)	Use RA 37 rack adapter	1/4, 1/2, 3/4 rack size
	Mounting "ears" supplied	Full rack size
Cooling	Forced air	Exhaust to rear
Dimensions (HxWxD) inches mm	57 <sup>3</sup> / <sub>32</sub> x 45 <sup>5</sup> / <sub>32</sub> x 17 <sup>1</sup> / <sub>8</sub>	1/4 rack size
	132.6 x 105.6 x 435.0	
	add 2½"	
	57 <sup>3</sup> / <sub>32</sub> x 81 <sup>1</sup> / <sub>32</sub> x 17 <sup>9</sup> / <sub>64</sub>	1/2 rack size
	132.6 x 211.9 x 435.4	
rear for connector protrusion	inches mm	3/4 rack size
	57 <sup>3</sup> / <sub>32</sub> x 121 <sup>7</sup> / <sub>32</sub> x 17 <sup>9</sup> / <sub>64</sub>	
	132.6 x 318.3 x 435.4	
	inches mm	Full rack size
	63 <sup>1</sup> / <sub>32</sub> x 19 x 20 <sup>1</sup> / <sub>64</sub>	
	177 x 482.6 x 504.8	
Finish: Fed Std 595	Dark & light gray, color 26440	Front panel, 2 tone
Weight (packed for shipment)	18lb (8.2Kg)	1/4 rack size (50W)
	20lb (9.1Kg)	1/4 rack size (100W)
	38lb (17.3Kg)	1/2 rack size
	57lb (25.9Kg)	3/4 rack size
	96lb (43.6Kg)	Full rack size

(1) 325V model uses FET. (2) 0-6V models: 0.25V.

**OUTLINE  
DIMENSIONAL  
DRAWINGS**

Fractional dimensions  
in light face type  
are in inches,  
**dimensions in  
bold face type  
are in millimeters.**  
Tolerance:  $\pm 1/64"$  (**0.4**)  
between mounting holes  
 $\pm 1/32"$  (**0.8**)  
other dimensions

**ATE QUARTER RACK / SIZE A & B**

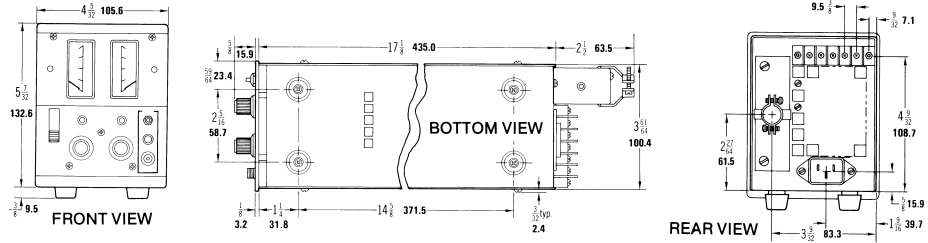

**ATE HALF-RACK  
SIZE C**

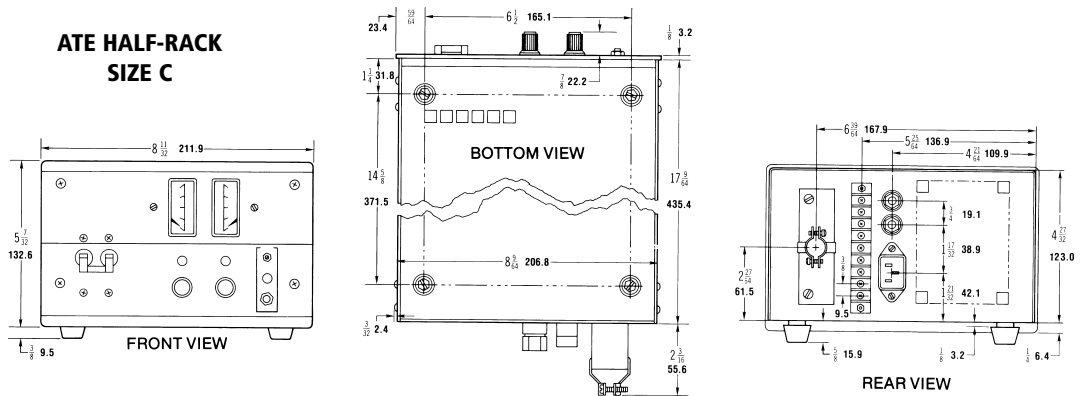

**ATE THREE-QUARTER-RACK / SIZE D**

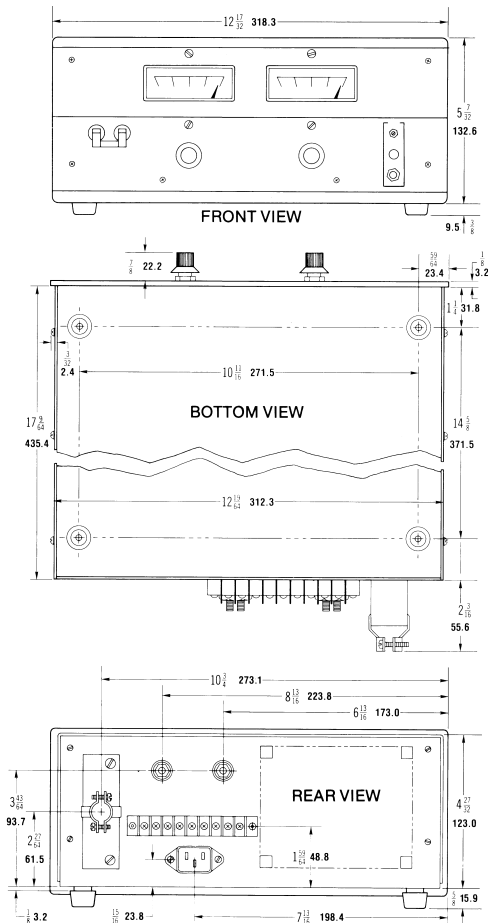

**ATE FULL RACK / SIZE E**

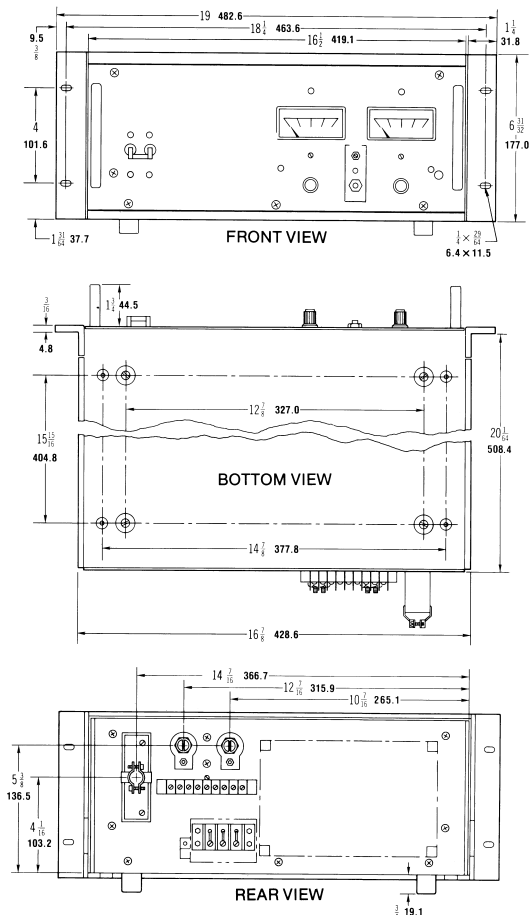

ATE 1/4 width, 1/2 width and 3/4 width power supplies can be rack mounted using RA 37. See page 77.