

Over 5000 VXI cards and mainframes in stock. 1000's of pieces of Test Equipment in stock.



Looking for Test Equipment?
Visit us on the web at
www.recycledequipment.com

Recycled Equipment buys, sells, and repairs VXI cards, VXI mainframes and Test Equipment. We have tens of thousands of pieces of Electronic Test Equipment and one of the worlds largest selections of VXI cards. We have VXI cards by almost every manufacture; from Agilent to Ziatech. **Every item on our website is IN STOCK and ready to ship with in 24 hours.**

Sell your equipment for cash

Recycled Equipment is interested in buying your surplus equipment! Call us today at **(410)685-1997** or email to **recycled@usimperio.com**

Sell your equipment on consignment

Recycled Equipment can sell your equipment on consignment. This allows you to get retail prices for your equipment with out the hassle.

(410)685-1997 sales@recycledequipment www.recycledequipment.com

Model SR1060

RESISTANCE STANDARDS & INSTRUMENTS

- Part-per-million transfers from 100 m Ω to 1 M Ω
- Thermally isolated by oil for maximum short-term thermal stability
- Excellent long-term stability; ± 20 ppm for 180 days
- Accuracy calibrated to ± 10 ppm
- Seven decades of resistance transfer
- 100:1 resistance transfers using series, parallel, series/parallel connection
- Calibration readings traceable to the NIST provided

Extremely Accurate and Stable

The Model SR1060 provides the part-per-million (ppm) resistance transfer accuracies and the long-term stabilities you need in today's modern metrology and calibration laboratories.

The SR1060 Resistance Transfer Standard is an extremely accurate, stable resistance standard that fits easily on a bench top or in a mobile, shock absorbed cart. It consists of six transfer standards in decades from 1 Ω to 100 k Ω . Each decade standard consists of 12 nominally equal resistors matched to within 10 ppm. In addition, each decade standard produces three decade values – 10 resistors in series (10R), 10 resistors in parallel (R/10), and nine of the 10 resistors in series/parallel (R). By making a 1:1 comparison with the tenth resistor, you can resolve a series-parallel value to better than 1 ppm.

Resistance Transfer Standard System

Oil Immersion Provides Thermal Isolation

All standards, except the 100 k Ω standard, are immersed in a mineral oil bath. Oil immersion provides thermal isolation to minimize the effects of ambient temperature variations. This means maximum short-term thermal stability for the standards. The SR1060 also exhibits superior long-term stability (± 20 ppm of nominal for six months; ± 35 ppm/two years). This gives you longer mean time between calibrations, increasing your calibration throughput.

As an added benefit, the oil bath speeds the dissipation of heat created in the

resistors during calibration. This heat dissipation further contributes to the stability of the standards.

O-Ring gaskets seal the SR1060 oil bath to keep your work surface and measuring contacts clean. The gaskets also minimize oil aging and contamination to lengthen the time between oil changes.

Since the 100 k Ω standard can be measured at much lower bridge power than the lower value standards, it is not necessary to immerse the standard in oil. However, this standard still benefits from the thermal lagging effects of the oil, because it is sealed in a chamber surrounded by oil.



TEGAM

THE GLOBAL SOURCE FOR PROVEN TEST
AND MEASUREMENT TECHNOLOGY.

Model SR1060

RESISTANCE TRANSFER STANDARD

Refining Resistance Technology

TEGAM's experience in the design and manufacture of resistance standards has made TEGAM standards highly-respected throughout government and industry. The SR1060 incorporates all the features of the SR1010 Resistance Transfer Standards with the many benefits of a sealed oil bath.

Ideal as a Multi-Value Standard Resistor or Reference Voltage Divider

The high accuracy and precision of the individual resistors make the SR1060 ideal for use as a multi-value standard resistor or reference voltage divider. The superior stability of the SR1060 makes it particularly suitable for calibrating 6-1/2, 7-1/2, and 8-1/2 digit Digital Multimeters.

Certified Traceable to the NIST

The SR1060 Resistance Transfer Standard System is certified traceable to the National Institute of Standards and Technology. You can use the SR1060 to transfer this traceability to your resistance standards and measuring equipment. Certified calibration data is supplied with every standard.

Specifications

Standard Values

1, 10, 100, 1 k, 10 k and 100 k Ω /step

Transfer Accuracy

100:1 $\pm(1 \text{ ppm} + 0.1 \mu\Omega)$ at parallel value*
 10:1 $\pm(1 \text{ ppm} + 1 \mu\Omega)$ at series or parallel value*

* with shorting bars, SB103, and compensation networks PC101 or SPC102

Initial Adjustment

± 20 ppm, matched within 10 ppm

Initial Calibration Certificate

± 10 ppm, NIST traceable

Calibration Conditions

23°C, low-power, four-terminal measurement, initial calibration readings are provided

Long-Term Resistance Stability

± 20 ppm of nominal for 6 months
 ± 35 ppm for 2 years

Temperature Coefficient

1 Ω ± 15 ppm/ $^{\circ}\text{C}$, matched within 5 ppm/ $^{\circ}\text{C}$
 10 Ω ± 1 ppm/ $^{\circ}\text{C}$
 100 Ω to 100 k Ω ± 5 ppm/ $^{\circ}\text{C}$, matched within 3 ppm/ $^{\circ}\text{C}$

Power Coefficient

1 Ω ± 0.3 ppm/mW/resistor typical
 10 Ω ± 0.02 ppm/mW/resistor typical
 100 Ω to 100 k Ω ± 0.1 ppm/mW/resistor typical

Power Rating

Single Step 1W/step
 10 in Series 5W/distributed

Leakage Resistance

Greater than $10^{12} \Omega$ terminal to case

Breakdown Voltage

1500 V peak to case

Oil Bath

Oil Mineral oil, USP Light, PENRECO, Sontex 85; insulation resistance typically $10^{14} \Omega$
 Housing Gasket sealed; fill, drain, and resistance probe ports provided

Dimensions

(oil bath, standards installed)
 Height 4.675 in. (118.75 mm)
 Width 16.000 in. (406.4 mm)
 Depth 30.000 in. (762.0 mm)

Weight

(oil bath, standards installed)
 94 lbs. 14.3 oz. (43.04 kg)

Operating Environment

Temperature 22.8°C $\pm 3.3^{\circ}\text{C}$
 Humidity 20 to 50% relative humidity

Safe Operating Environment

Temperature 0 to 50°C
 Humidity 15 to 80% relative humidity

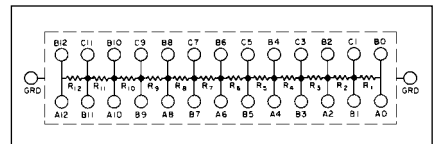

Maximum Current and Voltage Capabilities

| R Value | Per Step | 1 Ω | 10 Ω | 100 Ω | 1 k Ω | 10 k Ω | 100 k Ω |
|----------------------|----------|------------|-------------|--------------|--------------|---------------|----------------|
| Single Resistor | max mA | 1000 | 320 | 100 | 32 | 10 | 3.2 |
| | max V | 1 | 3.2 | 10 | 32 | 100 | 321 |
| 10 in Parallel, R/10 | max mA | 7100 | 2300 | 710 | 230 | 71 | 23 |
| | max V | 0.71 | 2.3 | 7.1 | 23 | 71 | 230 |
| 10 in Series, 10R | max mA | 710 | 230 | 71 | 23 | 7.1 | 2.3 |
| | max V | 7.1 | 23 | 71 | 230 | 710 | 2300* |

* Do not exceed 1500 V to case

OPTIONS AND ACCESSORIES

**Resistance Standard Cart
P/N 58359**

The Resistance Standard Cart (P/N 58359) is shock-absorbed to provide safe, stable storage and transportation in the laboratory environment. The cart is designed so that its top surface remains level to the floor within 1/8th inch so that, with the SR1060 in place, total unit dimensions and weight meet MLEE 84-21A requirements.

Cart Dimensions

Height 34.05 in. (864.87 mm)
 Width 16.00 in. (406.4 mm)
 Depth 30.00 in. (762.0 mm)

Cart Weight

47.0 lbs. (21.32 kg)

**Model PC101 Parallel
Compensation Network**

The Model PC101 Parallel Compensation Network is used in addition to the Model SB103 Shorting Bars for the four-terminal parallel connection of 10 low-value resistors in the Model SR1060 Resistance Transfer Standard System.

Effective Accuracy

Effect of connection resistances on four-terminal parallel value less than $\pm 0.1 \mu\Omega$.

Maximum Current

2A

Breakdown Voltage

1500 V peak to case

Dimensions

Height 1.0 in. (2.5 cm.)
 Width 12.0 in. (30.5 cm.)
 Depth 3.2 in. (8.1 cm)

Weight

1 lb. (454 gm) net
 R = Approx. 1Ω

**Model SPC102 Series/Parallel
Compensation Network**

The Model SPC102 Series/Parallel Compensation Network is used in addition to the Model SB103 Shorting Bars for the four-terminal series/parallel connection of nine low-value resistors in the Model SR1060 Resistance Transfer Standard System.

Effective Accuracy

Effect of connection resistances on four-terminal series/parallel values less than $\pm 1 \mu\Omega$.

Maximum Current

2A

Breakdown Voltage

1500 V peak to case

Dimensions

Height 1.0 in. (2.5 cm.)
 Width 12.0 in. (30.5 cm.)
 Depth 3.2 in. (8.1 cm)

Weight

1 lb. (454 gm) net
 R = Approx 1Ω

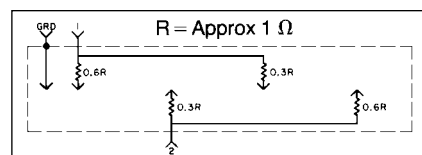
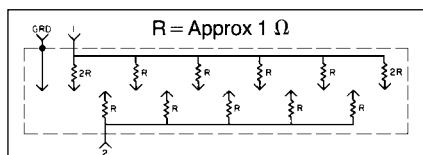

Model SR1060

RESISTANCE TRANSFER STANDARD

OPTIONS AND ACCESSORIES CONTINUED

SB103 Shorting Bars

The Model SB103 Shorting Bars are used to connect up to 12 resistors in the Model SR1060 Resistance Transfer Standard System in parallel or nine resistors in series/parallel. They may be used by themselves or in conjunction with the Model PC101 or SPC102 networks. The resistance that must be added to the value calculated from the individual resistor values is given in the accompanying table for two- and four-terminal measurements.

| Measurement and Accessories | 10 Resistors in Parallel (0.1R) | 9 Resistors in Series/Parallel (R) |
|---------------------------------------|---------------------------------|------------------------------------|
| Two-terminal SB103 | 150 ±30 μΩ | 300 ±60 μΩ |
| Four-terminal SB103 & PC101 or SPC102 | 0 ±0.1 μΩ | 0 ±1 μΩ |
| SB103 Alone | 50 ±10 μΩ | 200 ±40 μΩ |

Resistance

Approximately 100 μΩ/bar end to end

Maximum Current

10 A/bar

Dimensions (each bar)

Height 1.4 in. (3.55 cm.)

Width 9.5 in. (24.10 cm.)

Depth 0.8 in. (2.03 cm.)

Weight

8 oz. (227 gm.) net

Series/Parallel Connection

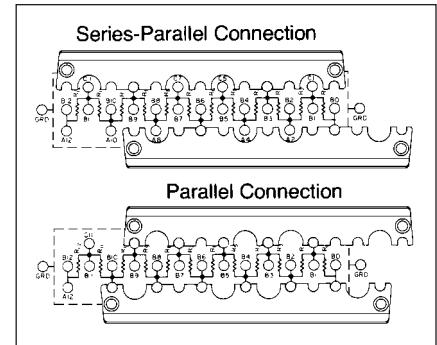

Calibration & Technical Services

For warranty and remedial repair, calibration services and spare parts, or for additional information on TEGAM sales and service offices around the world, contact us at **440-466-6100 (ph)** or **440-466-6110 (fx)**.



THE GLOBAL SOURCE FOR PROVEN TEST
AND MEASUREMENT TECHNOLOGY.

TEN TEGAM WAY • GENEVA, OHIO 44041
440-466-6100 • FAX 440-466-6110
www.tegam.com • e-mail: sales@tegam.com