

Over 5000 VXI cards and mainframes in stock. 1000's of pieces of Test Equipment in stock.



Looking for Test Equipment?  
Visit us on the web at  
[www.recycledequipment.com](http://www.recycledequipment.com)

Recycled Equipment buys, sells, and repairs VXI cards, VXI mainframes and Test Equipment. We have tens of thousands of pieces of Electronic Test Equipment and one of the worlds largest selections of VXI cards. We have VXI cards by almost every manufacture; from Agilent to Ziatech. **Every item on our website is IN STOCK and ready to ship with in 24 hours.**

### **Sell your equipment for cash**

Recycled Equipment is interested in buying your surplus equipment! Call us today at **(410)685-1997** or email to **recycled@usimperio.com**

### **Sell your equipment on consignment**

Recycled Equipment can sell your equipment on consignment. This allows you to get retail prices for your equipment with out the hassle.

**(410)685-1997 sales@recycledequipment www.recycledequipment.com**

## Discontinued Product Information — For Support Reference Only —

Information herein, may refer to products/services no longer supported. We regret any inconvenience caused by obsolete information. For the latest information on Agilent's test and measurement products go to: [www.agilent.com/find/products](http://www.agilent.com/find/products)

**In the US, call Agilent Technologies at 1-800-829-4444**  
(any weekday between 8am–5pm in any U.S. time zone)

World-wide Agilent sales office contact information is available at:  
[www.agilent.com/find/contactus](http://www.agilent.com/find/contactus)

### HP 87130A Attenuator/Switch Driver



# HP 87130A Attenuator/Switch Driver

- Control 31 switches, expandable to 248
- Simple Programming through HP-ITG and HP-VEE
- Switch position sensing
- User defined and labeled switch paths
- SCPI compatible

The HP 87130A Attenuator/Switch Driver simplifies the task of controlling and integrating up to 248 switches and/or step attenuator sections into RF and microwave ATE systems. HP-ITG and HP-VEE software drivers speed system programming for the HP 87130A. Switch driver boards provide switching signals and verify switch positions. Additional driver boards, interconnect boards, and cables provide expanded capacity, remote switching and everything needed for simple device connection.

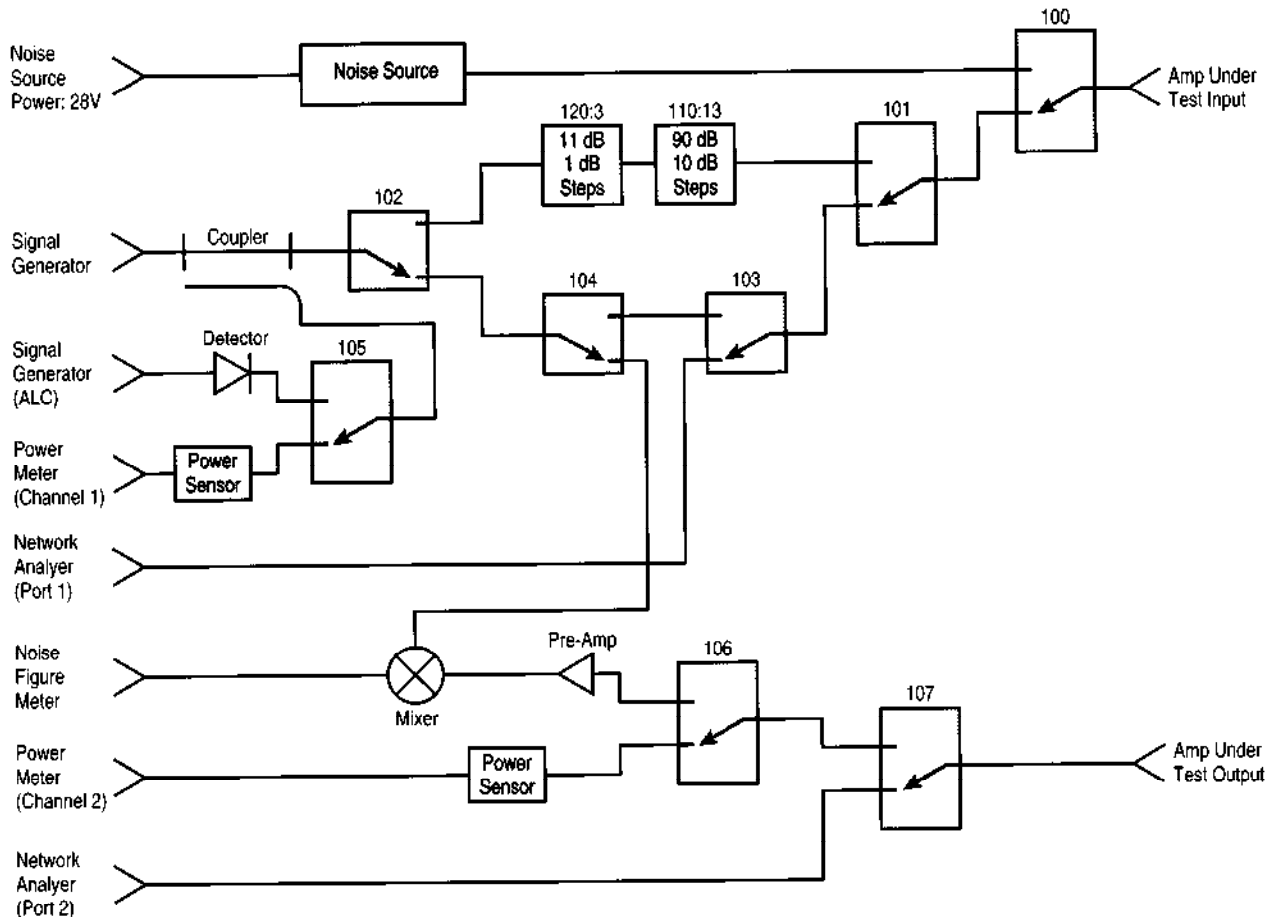

**Typical switching matrix-  
numbers indicate switch channels.**

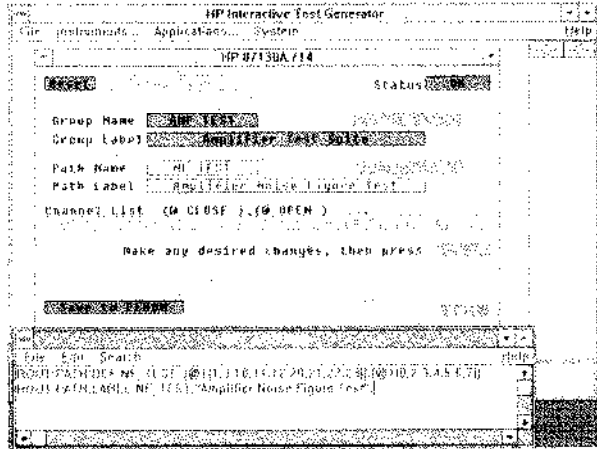

Figure 1.  
Path command

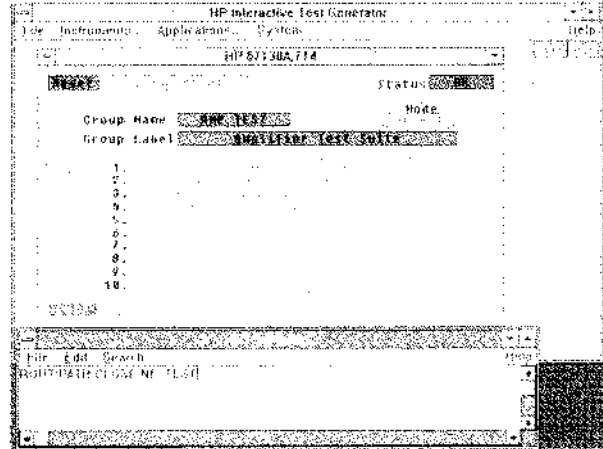

Figure 2.  
Group command

### Efficient programming

Set and verify switch positions with the interactive ITG and VEE visual interfaces. Rapidly generate program instructions with the powerful HP-ITG driver. Use the PATH command to combine the switch settings and to give it a meaningful name such as "Amplifier Noise Figure Test" (figure 1). Organize PATHs into custom menus with the GROUP command (figure 2).

### Simple hardware

Quickly expand the drive capability from 31 to 248 switches by adding up to seven external switch driver boards. Connect switches and step attenuators easily with switch signal distribution boards, step attenuator cables and switch cable harnesses.

### Block diagram and expandability

The HP 87130A is a self contained switch and step attenuator driver built into a 3 1/2 inch high, full rack width cabinet. Its internal power supply is sufficient to control and drive up to 248 external switches, the HP-IB/SCPI controller board, and the electro-mechanical switch and step attenuator driver board (figure 3). The controller board provides the HP-IB link and protocol management in addition to SCPI

command translation, storage for configuration information and translating and relaying QUERY results. The controller board communicates to the HP 84940A driver boards (one internal, up to 7 external) over a TTL level parallel data bus. The connection between the controller board and the driver boards provides both the power necessary to bias the driver board and the power required to drive the switches.

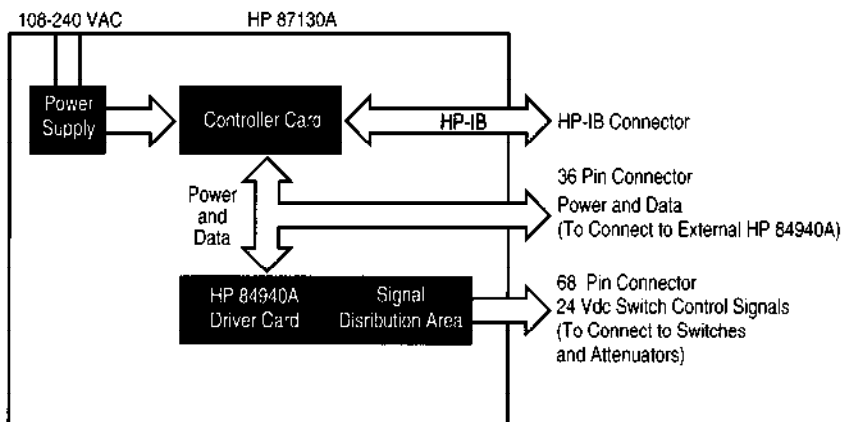

Figure 3.  
Block diagram

# Controlling the HP 87130A

## Reduce and preserve your software investment

The HP 87130A insures that software investment is preserved for the long term with SCPI (*Standard Commands for Programmable Instruments*) compatibility and is designed to simplify and speed test system software development. SCPI compatibility means that a common set of instrument control commands are used for similar operations. As a result, software developed for the HP 87130A today will work with the HP 70611A Modular Measurement System Switch Attenuator Driver and with future versions of SCPI compatible instruments. Extensions to the SCPI command set, built in EEROM, and optional software drivers provide very powerful features to reduce code development cost, system trouble shooting, and provide for manual control of the switching interface.

The test engineer has many choices available for controlling the HP 87130A. Whether it is through user provided control programs written in Instrument Basic, Rocky Mountain Basic, C, or Pascal or through test development environments such as the HP Integrated Test Generator (HP-ITG) or the HP Visual Engineering Environment (HP-VEE), all the features of the HP 87130A simplify the task of programming and controlling the switching interface.

## Precise control, the basics

Each switch or step attenuator section in the system is referred to as a CHANNEL. The HP 87130A has the capability to control up to 248 channels when it is fully expanded with eight HP 84940A driver cards. Each channel can be set to one of two possible states, either OPEN or CLOSE. Figure 4 shows how the channels are controlled. In HP-ITG the channel list shows all the driver cards and their channels which are available for switching. Each channel's state is indicated as being either open (inverse video) or closed (normal video). To change the state, the user simply uses the mouse pointer to click on the channel to toggle its state to either open or closed. When writing code, the open and close states are set via the:

```
"ROUTE:OPEN <channel list>"  
and  
"ROUTE:CLOSE <channel list>"
```

commands, where the channel list indicates the channels that will be set into the OPEN or CLOSE

states. While controlling a switching interface in this manner may be quite simple, it is not efficient in particularly large switching systems, where signal paths may include many switches, and where several different paths may be specified for use at one time. The HP 87130A incorporates powerful PATH commands to simplify programming and controlling complicated paths.

## Take the right path

Typically, in a switching system, signals are routed from one port to several other ports on a regular basis in order to perform a test or other function. In a large system, where there are many possible input to output port combinations, keeping the proper channel states straight and recalling them to achieve a particular routing can be a time-consuming job. In the HP 87130A the PATH command allows the test engineer to define often used channel lists, give short logical names to channel lists, self document channel lists, and recall channel lists.

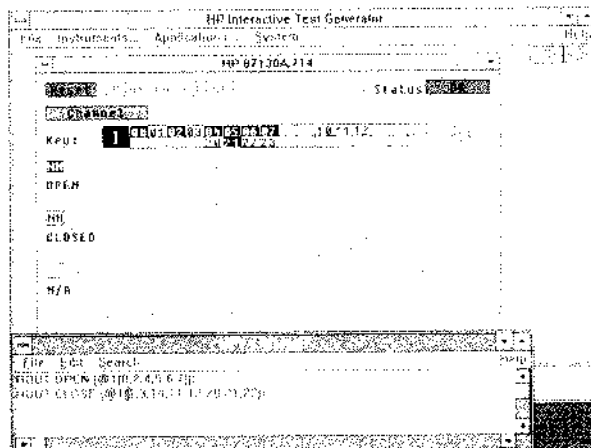

Figure 4. Channel commands

A Path is defined as a predetermined set of OPEN and CLOSED channels. While it is possible to just call this path "Path 1", it would be better to give it a meaningful name to make it easy to remember what it is for or what it does. Figure 1 is an example of how to define and name a path. The path definition includes channels lists for BOTH Closed and Open switches, along with a logical name assigned to this set of channels lists. In this example, the path is used for testing the noise figure of an amplifier, so the path has been given the name "NF\_TEST". It is also possible to give the path a more complete description by giving it a LABEL. This label is a self documenting feature in the HP 87130A, providing a more detailed description of the purpose of the path. Names and labels are stored in the HP 87130A, saving programming time and code overhead because they do not need to be defined within the program.

Recalling a path (Figure 2) is simply a matter of clicking on the desired path or issuing a simple, logical statement. Once again, for those generating code, the path name provides some degree of self documentation, making it very easy to see, within the program, what path this command is selecting.

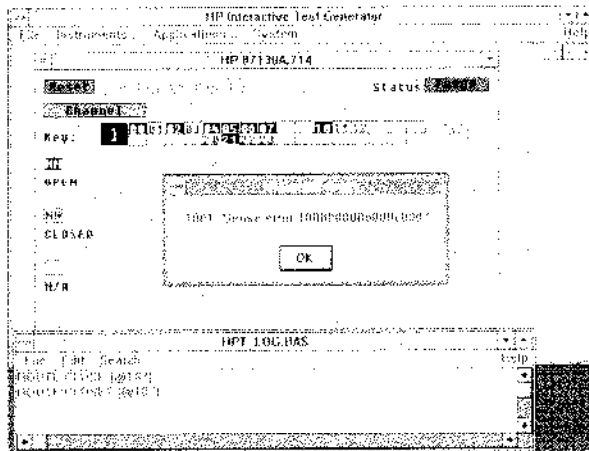

Figure 5.  
Error sensing

It is occasionally necessary to troubleshoot a switching interface to isolate and correct problems in the system. It is also frequently desirable to verify that channels are properly set before proceeding with the test program. The HP 87130A can query switches to determine if each channel is in its commanded state. In this way the user can isolate any switches which are not operating properly.

When used in conjunction with the OPEN and CLOSE commands, it is very easy to determine where the problem may lie and take steps to remedy the situation. Figure 5 shows the query forms of the CLOSE command in detail. This feature utilizes the HP 84940A's built in sensing circuits to determine the state a switch is in. It relies on the characteristic of self-interrupting switches to cease drawing current from its control source once switching is completed. Switches that do not self-interrupt will not work with this feature (table 1).



# Hardware

## Expansion

The basic HP 87130A contains a single HP 84940A Driver Card capable of powering and controlling 31 switches. When additional driver capability is required or when remotely switching from a centrally located system, up to 7 additional HP 84940A driver cards can be added externally, giving a total capacity of 248 switches (figure 7). The HP 84940A Driver Cards may be located up to 100 feet away from the HP 87130A. Typically these additional cards will be mounted inside the switching interface where the additional switching is required (figure 8).

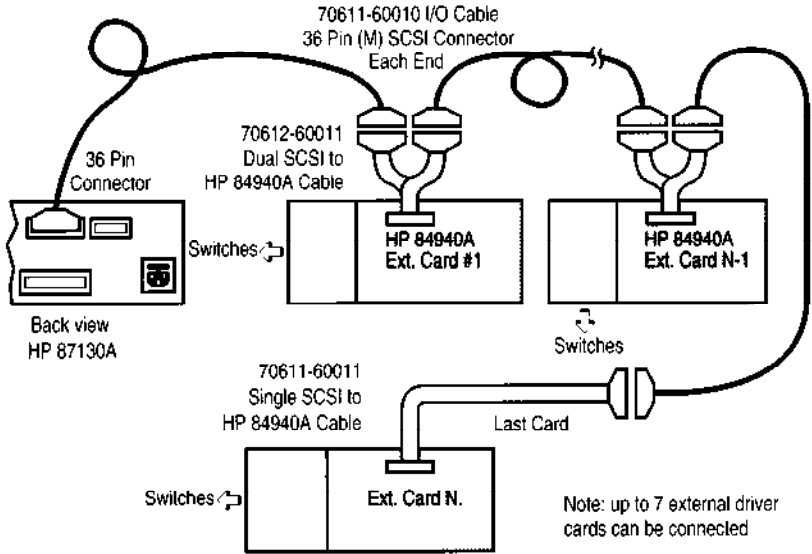

**Figure 7.**  
Expanding drive capability

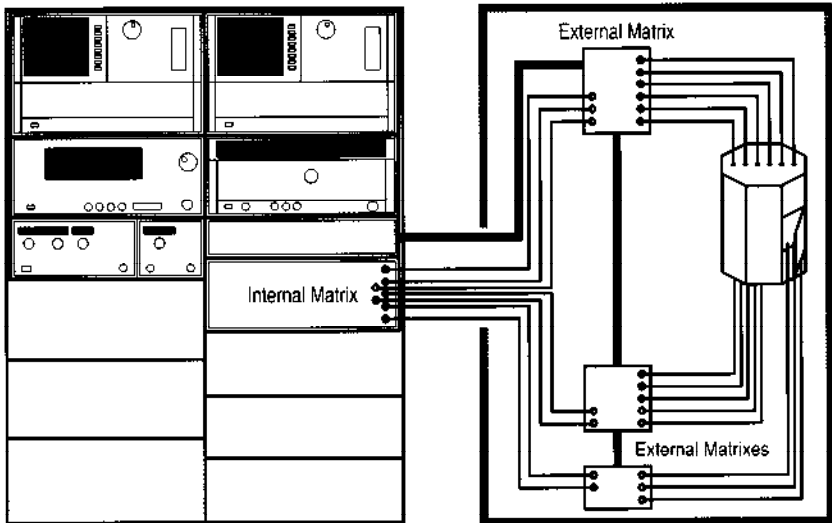

**Figure 8.**  
Satellite test

**Simple and quick hardware integration**

The HP 87130A can easily be integrated into any test system. In an application where the HP 87130A is directly controlling up to 31 switches, the recommended configuration is to use the HP 84941A Distribution Board with the HP 70611-60012 driver cable included with the HP 87130A (figure 9). The HP 84941A distributes the switch control signals to 31 4-pin connectors (figure 10). Each connector provides an OPEN and CLOSE signal and a common 24 Vdc supply. The connectors on the HP 84941A are polarized to prevent reversed connections. Miswiring the +24 V wire will cause catastrophic driver board failure.

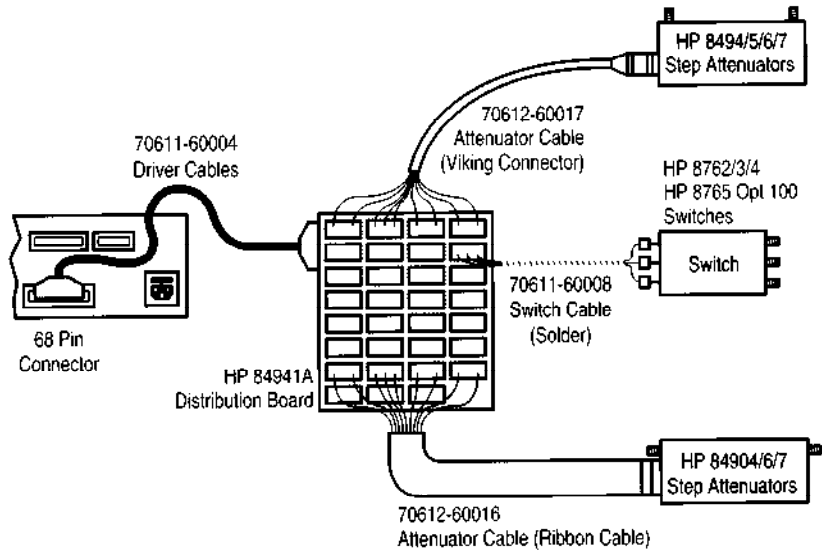

**Figure 9.**  
**Connecting device**

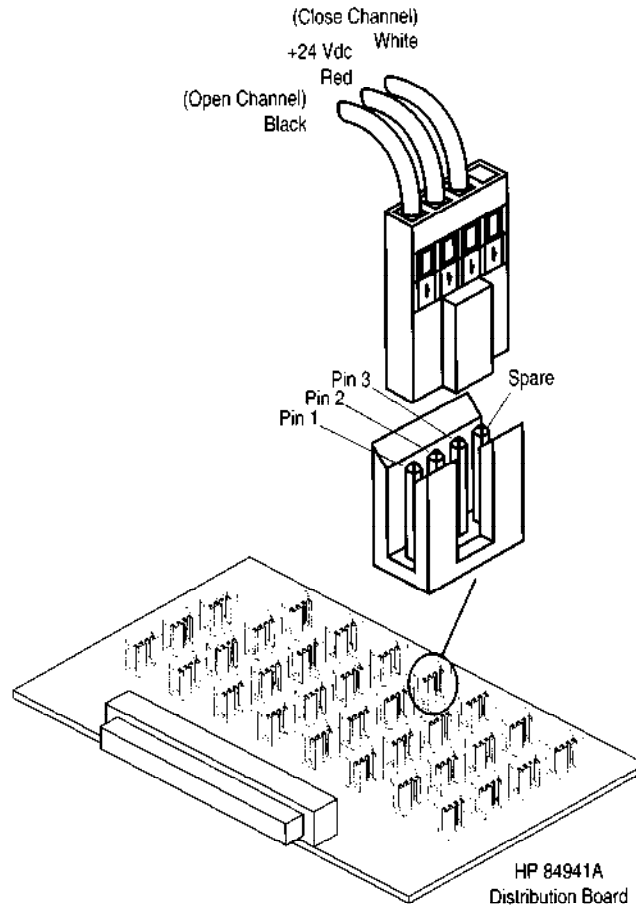
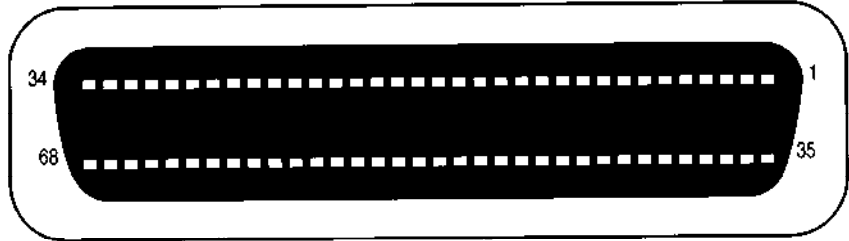

**Figure 10.**  
**Single typical switch channel connector**



The board is designed to drive + 24 Vdc switches which are switched by sinking the control pins to ground. The HP 84940A has a 68 pin connector (figure 12a) for directly driving attached switches and a dual inline connector to communicate with the controller board. When using only a single external HP 84940A driver board, it should be connected to the HP 87130A using the HP 70611-60011 interface cable, which is terminated to a single 36 pin high density connector (figure 12b). When attaching multiple driver cards, the HP 70611-60013 interface cable provides the connections necessary to connect to the controller card and additional driver cards. The last external HP 84940A Driver Card should be connected via the HP 70611-60011 so that the low impedance TTL pulses carried on the data bus do not cause emission problems (figure 8). All the cables necessary for quickly connecting the HP 84940A driver board to the HP 87130A are included with the HP 84940A.

The HP 84941A Distribution Board includes 32 prewired cables that can be used to directly connect switches to the distribution board. Additional cables are available in sets of 30 as HP 11764H.



**Figure 12a. HP 70611-60004**  
Standard output cable is a six-foot cable with two male, 68-pin SCSI II type connectors.

Pin	Function	Pin	Function
1	Return	35	Return
2	Channel 0, Open	36	Channel 0, Closed
3	Channel 1, Open	37	Channel 1, Closed
4	Channel 2, Open	38	Channel 2, Closed
5	Channel 3, Open	39	Channel 3, Closed
6	Channel 4, Open	40	Channel 4, Closed
7	Channel 5, Open	41	Channel 5, Closed
8	Channel 6, Open	42	Channel 6, Closed
9	Channel 7, Open	43	Channel 7, Closed
10	Channel 8, Open	44	Channel 8, Closed
11	Channel 9, Open	45	Channel 9, Closed
12	Channel 10, Open	46	Channel 10, Closed
13	Channel 11, Open	47	Channel 11, Closed
14	Channel 12, Open	48	Channel 12, Closed
15	Channel 13, Open	49	Channel 13, Closed
16	Channel 14, Open	50	Channel 14, Closed
17	Channel 15, Open	51	Channel 15, Closed
18	Channel 16, Open	52	Channel 16, Closed
19	Channel 17, Open	53	Channel 17, Closed
20	Channel 18, Open	54	Channel 18, Closed
21	Channel 19, Open	55	Channel 19, Closed
22	Channel 20, Open	56	Channel 20, Closed
23	Channel 21, Open	57	Channel 21, Closed
24	Channel 22, Open	58	Channel 22, Closed
25	Channel 23, Open	59	Channel 23, Closed
26	Channel 24, Open	60	Channel 24, Closed
27	Channel 25, Open	61	Channel 25, Closed
28	Channel 26, Open	62	Channel 26, Closed
29	Channel 27, Open	63	Channel 27, Closed
30	Channel 28, Open	64	Channel 28, Closed
31	Channel 29, Open	65	Channel 29, Closed
32	Channel 30, Open	66	Channel 30, Closed
33	Channel 31, Open	67	+24 Vdc
34	Channel 32, Open	68	Return

For step attenuators, two types of cables are available. The HP 11764E is terminated to 4 four-position connectors and a Viking connector for use with the HP 8494/5/6/7 step attenuators and the HP 8766/7/8/9 multiport switches. The second cable, the HP 11764F, incorporates a 14 position dual inline connector in place of the Viking connector for use with step attenuators with ribbon cable connectors such as the HP 84904/6/7 family of high performance step attenuators (figure 9).

Connecting switches and step attenuators to remotely mounted HP 84940A Driver Cards is also straightforward. The HP 84940A has a distribution section similar in layout to the HP 84941A (figure 11). Switches and step attenuators are connected in a similar fashion to the method described above. Switches or step attenuators located remote from the internal HP 84940A may be driven with an HP 70611-60012 cable and another HP 84941A Distribution Card.



**Figure 12b. HP 70611-60010**  
The standard I/O data cable is a five-foot cable with two female, 36-pin SCSI II type connectors.

Pin	Function	Pin	Function
1	Return	19	D6, Data Line
2	Return	20	D7, Data Line
3	NC	21	D8, Data Line
4	NC	22	D9, Data Line
5	NC	23	D10, Data Line
6	NC	24	D11, Data Line
7	+5 Vdc	25	D12, Data Line
8	+5 Vdc	26	D13, Data Line
9	+24 Vdc	27	D14, Data Line
10	+24 Vdc	28	NC
11	Return	29	NC
12	Return	30	Register CLR
13	D0, Data Line	31	Store
14	D1, Data Line	32	I/O
15	D2, Data Line	33	Return
16	D3, Data Line	34	Return
17	D4, Data Line	35	NC
18	D5, Data Line	36	NC

### Accessories

The HP 87130A is designed to translate commands delivered over an HP-IB link into switch controlling actions. It will operate with most PCs and workstations equipped with an HP-IB port and running HP-ITG, HP-VEE or a user written program. It is compatible with Hewlett-Packard's

microwave switches and step attenuators (table 1) and many switches from other vendors. Since it drives a switch by providing a temporary current pulse, it will not work with non-latching or failsafe switches that require current to be applied constantly to hold a position.

# Specifications

## Electrical

### Drive Capacity

*Internal Driver* 31 relays. One HP 84940A driver card is installed within the instrument.

*External Drivers* 217 additional relays. Up to 7 additional HP 84940A driver cards can be daisy-chained external to the HP 87130A. Each HP 84940A can drive 31 relays.

### Voltage

+24 volts  $\pm 3.0$  Vdc

Miswiring the +24 V wire will cause catastrophic driver board failure.

### Current Pulses

800 mA maximum per four relay group. 200 mA per relay. Default pulse width is 30 msec. Pulse width is adjustable from 5 ms to 1275 ms  $\pm 5$  ms, in 5 ms steps.

### Load Inductance

Typically <500 mH.

### Load Capacitance

Typically < 0.01  $\mu$ F.

## Switching Speed

Sensing delay is adjustable, per relay, from 5 to 1275 ms  $\pm 5$  ms. Pulse width is also adjustable, per relay from 5 to 1275 ms  $\pm 5$  ms. The final switching speed is a function of pulse widths, sensing delays, the sequence of relays driven, and the state of the chosen channels.

## Remote Programming

All functions are HP-IB programmable except the line switch and bus address. All functions are programmable to conform with IEEE 488.2-1987 Standard Commands for Programmable Instruments (SCPI). The HP 87130A can output over the interface almost all settings, error/malfunction codes and operation status.

### Interface to

#### External Drivers

36-pin SCSI II type connector

### Interface to

#### External Switches

68-Pin SCSI II type connector

### Interface to

#### Controller

HP-IB IEEE-488 standard connector

## Environmental

### Temperature

*Operating* -5° C to +60° C

*Survival* -40° C to +70° C

### Humidity

95% relative humidity at 40° C max

### Altitude

*Operating*

4,600 meters (15,000 feet)

*Non-Operating*

15,300 meters (50,000 feet)

### Vibration

*Operating* 0.21 g (rms)

*Survival* 2.1 g (rms)

*Swept Sine* 0.5 g (pk)

### Shock

*End use*

350 g (pk) for 3 ms duration

*Transportation*

100 g (pk) for 30 ms duration

### Electromagnetic

#### Compatibility Military Specs

Conducted and radiated interference is in compliance with CISPR, Pub 11 (1985) and Messemphaenger-Postferfuegung 526/527/79 (Kennzeichnung Mit F-Nummer/Funkschutzzeichen). Meets the requirements of MIL-STD-461B.

### Maximum

#### Power Dissipation

110 Watts

### Weight

3.2 kg (7 lbs)

### Dimensions

*Height*

102 mm (4 inches including feet)

*Width*

425.4 mm (16.75 inches)

*Depth*

502 mm (19.75 inches)

Allow 3 inches of clearance in back for cables.

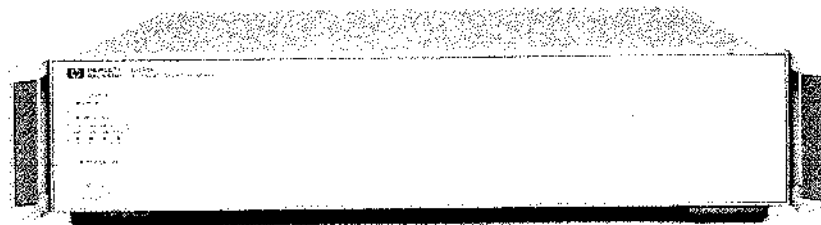

## Ordering and Configuration Information

### **HP 87130A**

Attenuator/Switch Driver HP-IB/SCPI switch and step attenuator driver will drive up to 31 switches or step attenuator sections. Includes one HP 70611-60004 1.83 meter switch signal interface cable and a rack mount kit.

### **HP 84940A**

Switch Driver Card will drive up to 31 switches. The card kit includes the HP 70611-60010 cable to connect to the HP 87130A and one each of the HP 70612-60011 and HP 70611-60013 interface cables for mounting the driver card into an external cabinet. (Each HP 87130A can control up to 7 HP 84940A Switch Driver Cards.)

### **HP 84941A**

Switch Interface Kit includes a switch signal distribution card, which interfaces to the signal interface cable included with the HP 87130A, and 31 3-wire switch interface cables for building cable harnesses.

### **Controller Hardware and Software**

The HP 87130A can be controlled by a wide variety of PC and Workstation based controllers.

As a minimum any 100% PC compatible computer may be used as a controller when used with an HP-IB interface card.

### **PC Hardware and Software** *HP 82335B*

HP-IB interface card and command library for MS-DOS and Windows 3.0. It works with all HP Vectra computers, in addition to IBM PC, PC/XT, PC/AT and all true IBM PC compatibles. The command library supports most popular programming languages.

### *HP 82300D*

Measurement Coprocessor. Designed for an IBM-AT or compatible ISA or EISA bus. This 68000 based coprocessor provides its own operating system, processor, HP-IB port, and RAM. It provides HP BASIC control over instruments on the bus.

### *HP 82324B*

High Performance Measurement Coprocessor. Provides much of the same functionality of the HP 82300D but with the power and speed of a 68030 processor.

### *HP E2020A*

HP Interactive Test Generator for DOS. Provides virtual front panel, instrument drivers and interactive HP BASIC code generation.

Options include:

335: Delete HP-IB Interface card  
AA6: Media on 5.25 in 1.2 MB disk  
AA8: Media on 3.5 in 1.44 MB disk

Hewlett-Packard's HP 9000 Series 300 Controllers offer powerful control options for the most demanding test and measurement needs. Depending upon your specific software and hardware needs, HP BASIC/WS, HP BASIC/UX and HP-VEE are available for developing test software and controlling test equipment. Consult with your HP sales representative for more information on available hardware and software for HP workstations.

**Table 1****HP Compatible Step Attenuators**

HP Model	Frequency	Description	Sense	HP OEM Equivalent	Order Option	Order Cable
8494G	dc - 4 GHz	0-11 dB, 1 dB steps	yes	33320G	Std	11764E
8494H	dc - 18 GHz	0-11 dB, 1 dB steps	yes	33320H	Std	11764E
8495G	dc - 4 GHz	0-70 dB, 10 dB steps	yes	33321H	Std	11764E
8495H	dc - 18 GHz	0-70 dB, 10 dB steps	yes	33321G	Std	11764E
8495K	dc - 26.5 GHz	0 - 70 dB, 10 dB steps	yes	33321K	Std	11764E
8496G	dc - 4 GHz	0-110 dB, 10 dB steps	yes	33322H	Std	11764E
8496H	dc - 18 GHz	0-110 dB, 10 dB steps	yes	33322G	Std	11764E
8497K	dc - 26.5 GHz	0-90 dB, 10 dB steps	yes	33323K	Std	11764E
84904K	dc - 26.5 GHz	0-11 dB, 1 dB steps	yes	33324K	Std	11764F
84904L	dc - 40 GHz	0-11 dB, 1 dB steps	yes	33324L	Std	11764F
84904M	dc - 50 GHz	0-11 dB, 1 dB steps	yes	33324M	Std	11764F
84906K	dc - 26.5 GHz	0-90 dB, 10 dB steps	yes	33326K	Std	11764F
84906L	dc - 40 GHz	0-90 dB, 10 dB steps	yes	33326L	Std	11764F
84906M	dc - 50 GHz	0-90 dB, 10 dB steps	yes	33326M	Std	11764F
84907K	dc - 26.5 GHz	0-70 dB, 10 dB steps	yes	33327K	Std	11764F
84907L	dc - 40 GHz	0-70 dB, 10 dB steps	yes	33327L	Std	11764F
84907M	dc - 50 GHz	0-70 dB, 10 dB steps	yes	33327M	Std	11764F

**HP Compatible Switches**

HP Model	Frequency	Description	Terminated	Sense	HP OEM Equivalent	Order Option	Order Cable
8762A	dc - 4 GHz	SPDT	yes	yes	33311A	Std	11764H *
8762B	dc - 18 GHz	SPDT	yes	yes	33311B	Std	11764H *
8762C	dc - 26.5 GHz	SPDT	yes	yes	33311C	Std	11764H *
8763A	dc - 4 GHz	Transfer	yes	yes	33312A	Std	11764H *
8763B	dc - 18 GHz	Transfer	yes	yes	33312B	Std	11764H *
8763C	dc - 26.5 GHz	Transfer	yes	yes	33312C	Std	11764H *
8764A	dc - 4 GHz	5 port	no	yes	33313A	Std	11764H *
8764B	dc - 18 GHz	5 port	no	yes	33313B	Std	11764H *
8764C	dc - 26.5 GHz	5 port	no	yes	33313C	Std	11764H *
8765A	dc - 4 GHz	SPDT	no	no	33314A	024 & 100	11764H *
8765B	dc - 20 GHz	SPDT	no	no	33314B	024 & 100	11764H *
8765C	dc - 26.5 GHz	SPDT	no	no	33314C	024 & 100	11764H *
8765D	dc - 40 GHz	SPDT	no	no	33314D	024 & 100	11764H *
8765F	dc - 4 GHz	75 ohm SPDT	no	no		024 & 100	11764H *
87104A	dc - 4 GHz	SP4T	yes	yes		Std	11764G
87104B	dc - 20 GHz	SP4T	yes	yes		Std	11764G
87104C	dc - 26.5 GHz	SP4T	yes	yes		Std	11764G
87106A	dc - 4 GHz	SP6T	yes	yes		Std	11764G
87106B	dc - 20 GHz	SP6T	yes	yes		Std	11764G
87106C	dc - 26.5 GHz	SP6T	yes	yes		Std	11764G

\* The HP 84941A Signal Distribution Board includes the HP 11764H cable set (enough cables to connect 31 switches). For reordering switch and attenuator interface cables see next page.

When additional integration accessories are required in order to complete a switching system, individual items may be ordered from a Hewlett-Packard Parts Center. The following accessories may be ordered individually:

**HP 11764E**

*Ribbon cable connector to Distribution Board*

Extra Viking cable connector to interface HP 8494/5/6/7 Step Attenuators to the HP 84941A Distribution Board or HP 84940A Driver Board signal distribution section. 1 cable.

**HP 11764F**

*Ribbon cable connector to Distribution Board*

Extra ribbon cable connector to interface HP 84904/6/7 Step Attenuators to the HP 84941A Distribution Board or HP 84940A Driver Board signal distribution section. 1 cable.

**HP 11764G**

*Ribbon cable to Distribution Board*

Extra ribbon cable connector to interface HP 87104/6 Multiport Switch to the HP 84941A Distribution Board or HP 84940A Driver Board signal distribution section. 1 cable.

**HP 11764H**

*Switch Interface Cable Kit*

Additional cables for use with the HP 84940A Driver Board or the HP 84941A Distribution Board for connecting switches. Package of 31 cables.

**HP 70611-60004**

*Switch Driver Cable*

Extra 68 pin female SCSI type connector (both ends) for connecting devices to the 68 pin male SCSI type switch driver connector on the HP 87130A. 1 cable.

**HP 70611-60010**

*Driver Control Cable*

Extra driver cable for connecting the HP 87130A to the HP 84940A. 1 cable.

**HP 70611-60011**

*HP 84940A Interface Cable*

Extra 34 pin PC board connector to 36 pin SCSI type male bulk-head connector for connecting an HP 84940A to the HP 70611-60010 Driver Control Cable. 1 cable.

**HP 70612-60011**

*HP 84940A Dual Interface Cable*

Extra 34 pin PC board connector to two 36 pin male SCSI type connectors for connecting an HP 84940A and daisy chaining additional HP 84940As. 1 cable.



### Agilent Email Updates

[www.agilent.com/find/emailupdates](http://www.agilent.com/find/emailupdates)

Get the latest information on the products and applications you select.



### Agilent Direct

[www.agilent.com/find/agilentdirect](http://www.agilent.com/find/agilentdirect)

Quickly choose and use your test equipment solutions with confidence.



[www.agilent.com/find/open](http://www.agilent.com/find/open)

Agilent Open simplifies the process of connecting and programming test systems to help engineers design, validate and manufacture electronic products. Agilent offers open connectivity for a broad range of system-ready instruments, open industry software, PC-standard I/O and global support, which are combined to more easily integrate test system development.

## www.agilent.com

### Agilent Technologies' Test and Measurement Support, Services, and Assistance

Agilent Technologies aims to maximize the value you receive, while minimizing your risk and problems. We strive to ensure that you get the test and measurement capabilities you paid for and obtain the support you need. Our extensive support resources and services can help you choose the right Agilent products for your applications and apply them successfully. Every instrument and system we sell has a global warranty. Two concepts underlie Agilent's overall support policy: "Our Promise" and "Your Advantage."

#### Our Promise

Our Promise means your Agilent test and measurement equipment will meet its advertised performance and functionality. When you are choosing new equipment, we will help you with product information, including realistic performance specifications and practical recommendations from experienced test engineers. When you receive your new Agilent equipment, we can help verify that it works properly and help with initial product operation.

#### Your Advantage

Your Advantage means that Agilent offers a wide range of additional expert test and measurement services, which you can purchase according to your unique technical and business needs. Solve problems efficiently and gain a competitive edge by contracting with us for calibration, extra-cost upgrades, out-of-warranty repairs, and onsite education and training, as well as design, system integration, project management, and other professional engineering services. Experienced Agilent engineers and technicians worldwide can help you maximize your productivity, optimize the return on investment of your Agilent instruments and systems, and obtain dependable measurement accuracy for the life of those products.

**For more information on Agilent Technologies' products, applications or services, please contact your local Agilent office.**

#### Phone or Fax

##### United States:

(tel) 800 829 4444  
(fax) 800 829 4433

##### Canada:

(tel) 877 894 4414  
(fax) 800 746 4866

##### China:

(tel) 800 810 0189  
(fax) 800 820 2816

##### Europe:

(tel) 31 20 547 2111

##### Japan:

(tel) (81) 426 56 7832  
(fax) (81) 426 56 7840

##### Korea:

(tel) (080) 769 0800  
(fax) (080) 769 0900

##### Latin America:

(tel) (305) 269 7500

##### Taiwan:

(tel) 0800 047 866  
(fax) 0800 286 331

##### Other Asia Pacific Countries:

(tel) (65) 6375 8100  
(fax) (65) 6755 0042

Email: [tm\\_ap@agilent.com](mailto:tm_ap@agilent.com)

Contacts revised: 09/26/05

**The complete list is available at:  
[www.agilent.com/find/contactus](http://www.agilent.com/find/contactus)**

Product specifications and descriptions in this document subject to change without notice.

© Agilent Technologies, Inc. 1992, 2006  
Printed in USA, July 11, 2006  
5091-3268E



## Agilent Technologies